

PRODUCTION RELEASE & REVISION						
REV	DESCRIPT'N/BUYER	DWG No	PARTS No.	BY	CHK	DATE
A	INITIAL / NO BRAND	-----	50301993	S.A.PARK	N.C.PARK	10-05-M5

### CORNER MOUNT BRACKET INSTALLATION

- ▶ Attach the corner mount to the structure using the tapping screws (PTS1, M6x30L) as illustrated in the figure. The corner mount must be attached to a structure such as hardwood, wall stud, concrete or a suitable material capable of supporting the final mount assembly. The installer may need to change the method of mounting or hardware used depending on the corner material.

Align the (wall) mount bracket holes to the corner mount plate holes and secure the bracket using the machine screws (M6x20L).

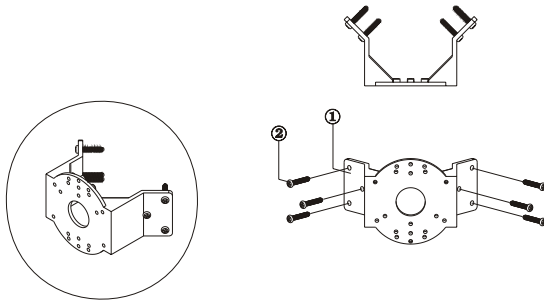

[ INSTALLING PLATE AT THE WALL ]

[ CORNER MOUNT ASS'Y - EXPLODED VIEW ]

#### ▶ PART LIST

NO	PART NAME	QTY	DESCRIPTION
1	CORNER MOUNT PLATE	1	Aluminum, light gray polyester powder coat
2	TAPPING SCREW	6	T1+BH, M6x30L
3	MACHINE SCREW	6	PH M6X20L

Instruction Manual

PRINTED IN KOREA  
50301993A

210(+/-3)mm

148(+/-3)mm

### NOTES

- MODEL: **HCM150 / All Brand**
- MATERIAL: 일반인쇄용지 (WHITE)  
BIND : -----
- FINISH: -----
- COLOR: TEXT-BLACK
- SIZE: 148(+/-5)mm x 210(+/-5)mm R: 0.0
- ANY CHANGE OR ALTERNATION MUST BE APPROVED BY HITRON ENGINEERING.

의견	전자	안전규격	기구설계	영업
			김형관 김환인 담당원	천상현 박인 담당원
			09/30/M5	10/05/M5

**도급품 50301993**

ITEM		DESCRIPTION/MATERIAL		QTY
PARTS LIST				
<b>HITRON</b>				
UNLESS OTHERWISE SPECIFIED ALL DIMENSIONS ARE IN MM. TOLERANCE LABEL +/- 1.5 MANUAL +/- 3.5 ANGULAR +/- 0.5		APPROVALS	DATE	
MATERIAL		CHKED		
FINISH		DRAWN		
		N.C.PARK	10-05-M5	
		S.A.PARK	10-05-M5	
TITLE		MANUAL INSTRUCTION		
SIZE	DWG No	REV.		
A4	-----	A		
SCALE		DO NOT SCALE		

## **CORNER MOUNT BRACKET INSTALLATION**

- Attach the corner mount to the structure using the tapping screws (PTS1, M6x30L) as illustrated in the figure. The corner mount must be attached to a structure such as hardwood, wall stud, concrete or a suitable material capable of supporting the final mount assembly. The installer may need to change the method of mounting or hardware used depending on the corner material.

Align the (wall) mount bracket holes to the corner mount plate holes and secure the bracket using the machine screws (M6x20L).

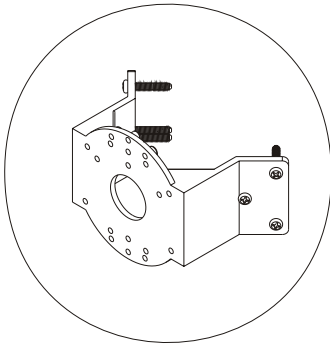

[ INSTALLING PLATE AT THE WALL ]

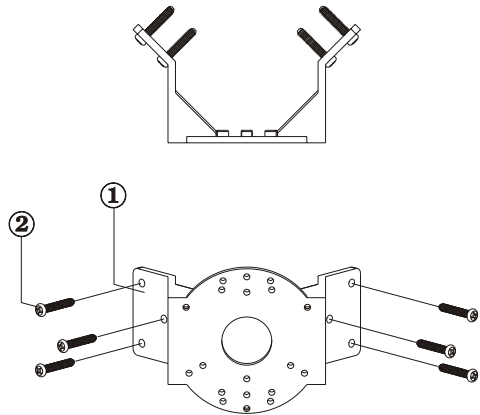

[ CORNER MOUNT ASS'Y - EXPLODED VIEW ]

### ➤ PART LIST

NO	PART NAME	Q'TY	DESCRIPTION
1	CORNER MOUNT PLATE	1	Aluminum, light gray polyester powder coat
2	TAPPING SCREW	6	T1+BH, M6x30L
3	MACHINE SCREW	6	PH M6X20L