

540TVL ELECTRONIC DAY / NIGHT
HI-RESOLUTION COLOR CAMERA



Lens Not Included

540TVL ELECTRONIC DAY / NIGHT COLOR CAMERA

C540EDNVL

- ▶ High Image Quality (540TVL) w/Excellent Color Reproduction
- ▶ 1/3" Sony Super-HAD CCD
- ▶ Electronic Day / Night
- ▶ Auto Electronic Shutter 1/60 (1/50 ~ 1/100,000) and Manual Electronic Shutter Modes
- ▶ Ultra Sensitivity Minimum Illumination of 0.25 Lux (Color), 0.01 Lux (B&W) @ F1.2, 50 IRE
- ▶ Super Back Light Compensation
- ▶ Auto Gain Control (AGC)
- ▶ Auto Trace White Balance Modes
- ▶ C/CS Lens Mount, Tool-less Back Focus Ring for Easy Adjustment
- ▶ Dual Power Operation 12VDC / 24VAC

540TVL ELECTRONIC DAY / NIGHT COLOR CAMERA

C540EDNVL

VALUE LINE SERIES

SPECIFICATIONS

MODEL		C540EDNVL ~ 540TVL Electronic Day / Night Color Camera
P O W E R	Power Source	24 VAC & 12 VDC +/-10%
	Power Consumption	4.0 Watts
G E N E R A L	Image Sensor	1/3" Super-HAD Color CCD (SONY)
	Total Number of Pixels	811(H) x 508(V)
	Scanning System	2:1 Interlace
	Scanning Frequency	15.734KHz(H) x 59.94Hz(V)
	Operating Temperature	14°F ~ 122°F (-10°C ~ +50°C)
	Sync. System	Internal / Line Lock
V I D E O	Electronic Shutter	1/60 ~ 1/100,000 sec.
	Signal Format	NTSC 525 lines
	Resolution	540 TVL
	Min. Illumination	Color (0.25 Lux) @ F1.2 50 IRE
	Video Output	1.0 Vp-p, (75 ohm Composite)
S/N Ratio	>50dB (AGC OFF)	
F U N C T I O N	White Balance	ATW Fixed
	AGC	On/Off
	Auto Iris Control	DC / Video
	BLC	On / Off
	Day & Night	Auto / Fixed Color
C O N N E C T O R	Video Output	BNC Connector
	Power Input	2-Pin Terminal Block
	Auto Iris Output	4-Pin Mini Din Jack (Standard connection)
	Lens Mount	C/CS Mount (Selected through back focus)
	Mounting Hole	1/4"-20 UNC (Top or Bottom)
	External Dimension	2.6"W x 2.2"H x 4.7"D (66W x 56H x 120D mm)
	Weight (Unit)	0.562 lbs. (255g)
	Conformity Certifications	FCC, UL, CE, RoHs

DIMENSIONS

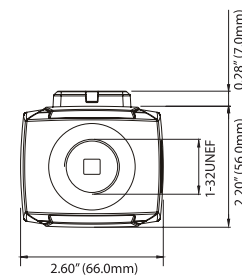
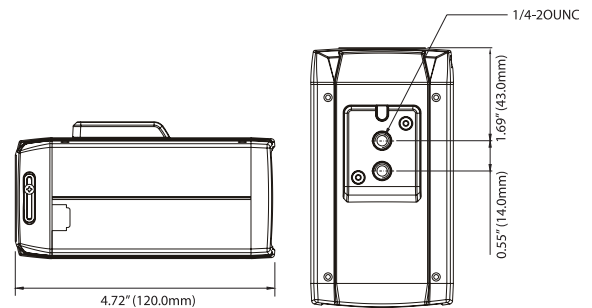

REAR VIEW



ACCESSORIES

Lenses:

A-LTV2Z3314GCS	3.3~8mm Varifocal DC Auto-Iris Lens
SCV55014DC	5~50mm Varifocal DC Auto-Iris Lens
SCV2812ASIR	2.8~12mm Varifocal DC Auto-Iris Lens

Mounts:

CM-TBAR	Camera Mount for Drop Ceiling "T-bar"
CMD16W	Camera Wall/Ceiling Mount (White)
CMD16B	Camera Wall/Ceiling Mount (Black)

Environmental Housing:

HT1203N	Camera Housing w/Heater-Blower
---------	--------------------------------

Housing Mounts:

HMW13	Medium Duty Wall/Ceiling Mount
A-CM150	Corner Mount Bracket for HMW13
A-CM151	Pole Mount Bracket for HMW13
A-CS164A	Pipe/Pole Mount Arm for HT1203N

Power Supplies:

P3AC24-16-25CB	16 channel, 24VAC, 25A circuit breaker
P3AC24-8-12CB	8 channel, 24VAC, 12A circuit breaker
P3AC24-4-4CB	4 channel, 24VAC, 4A circuit breaker
P3AC24-4-7CB	4 channel, 24VAC, 7.25A circuit breaker
P3DC12-8-10CB	8 channel, 12VDC, 10A circuit breaker w/power cord
RT2440SL	24VAC, 40VA transformer, UL

